

5G and Beyond: Key Challenges and Emerging Trends in Wireless Communication Systems



06

Ashish Kumar Gupta

The ICFAI University, Dehradun

Dr. Gaurav Bhandari

The ICFAI University, Dehradun

Prof. (Dr.) Ramesh Chand Ramola

The ICFAI University, Dehradun

Dr. Shabnam Arad

Shivalik College of Engineering Dehradun

Ch.Id:-NSP/EB/GTRDBAIP/2026/Ch-06

ABSTRACT

The evolution of wireless communication systems toward fifth-generation (5G) networks has enabled unprecedented capabilities in terms of enhanced mobile broadband (eMBB), ultra-reliable low-latency communication (URLLC), and massive machine-type communication (mMTC). Despite these advancements, 5G systems face significant challenges related to spectrum utilization, energy efficiency, network scalability, and reliability under dense deployment scenarios. This chapter presents a comprehensive technical analysis of the key challenges in 5G and beyond wireless communication systems, including spectrum scarcity in sub-6 GHz and millimeter-wave bands, hardware constraints in massive multiple-input multiple-output (MIMO) systems, interference management in ultra-dense heterogeneous networks, and security vulnerabilities in software-defined and virtualized network architectures. Furthermore, the role of advanced technologies such as beamforming, network slicing, edge computing, and artificial intelligence (AI)-driven network optimization is critically examined as potential enablers for next-generation systems. The chapter also explores emerging paradigms beyond 5G, including terahertz (THz) communication, intelligent reflecting surfaces (IRS), and integrated space-air-ground-sea networks envisioned for sixth-generation (6G) systems. The objective of this chapter is to provide a technically rigorous overview of challenges and solution frameworks, offering insights into the design and deployment of future wireless communication infrastructures.

Keywords: *5G Communication, 6G Networks, Wireless Communication, Massive MIMO, Millimeter Wave, Network Slicing, Spectrum Management, AI in Wireless Networks*

1. INTRODUCTION

Wireless communication systems have experienced unprecedented growth over the past few decades, evolving from basic voice-centric services in first-generation (1G) systems to high-speed, data-

centric applications in fifth-generation (5G) networks. This rapid evolution has been primarily driven by the exponential increase in mobile data traffic, proliferation of smart devices, and the emergence of data-intensive applications such as high-definition video streaming, virtual reality, autonomous systems, and the Internet of Things (IoT). As a result, modern communication systems are required to support diverse service requirements, including high data rates, ultra-low latency, massive connectivity, and enhanced reliability.

The deployment of 5G wireless communication systems represents a significant milestone in addressing these requirements. Unlike previous generations, 5G is designed to support three primary service categories: enhanced Mobile Broadband (eMBB), Ultra-Reliable Low-Latency Communication (URLLC), and massive Machine-Type Communication (mMTC). These service paradigms collectively enable a wide range of applications, from immersive multimedia services to mission-critical communications and large-scale IoT deployments. To achieve these capabilities, 5G incorporates advanced technologies such as massive multiple-input multiple-output (MIMO), millimeter-wave (mmWave) communication, beamforming techniques, and network virtualization.

Despite these advancements, the realization of 5G networks introduces several complex challenges. One of the primary concerns is spectrum scarcity, particularly in the sub-6 GHz frequency bands, which are already heavily congested. While millimeter-wave frequencies offer large bandwidth availability, they suffer from high propagation losses, susceptibility to blockage, and limited coverage. Furthermore, the deployment of massive MIMO systems, although beneficial for improving spectral efficiency, leads to increased hardware complexity, higher power consumption, and signal processing challenges.

Another critical challenge is network densification, which involves the deployment of a large number of small cells to enhance coverage and capacity. While densification improves network performance, it also introduces severe inter-cell interference, complex mobility management, and increased backhaul requirements. Additionally, ensuring energy efficiency in such dense networks remains a significant concern, particularly in the context of sustainable and green communication systems.

Security and privacy have also emerged as major challenges in 5G networks due to the adoption of software-defined networking (SDN), network function virtualization (NFV), and cloud-based architectures. These technologies, while enhancing flexibility and scalability, introduce new vulnerabilities and attack surfaces. Moreover, the integration of heterogeneous devices and networks further complicates the security landscape.

Looking beyond 5G, the vision of sixth-generation (6G) wireless communication systems aims to overcome the limitations of current networks and support futuristic applications such as holographic communication, digital twins, and intelligent autonomous systems. Emerging technologies such as terahertz (THz) communication, intelligent reflecting surfaces (IRS), and artificial intelligence-driven network management are expected to play a crucial role in enabling these capabilities. Additionally, the concept of integrated space-air-ground-sea communication networks is being explored to provide seamless global connectivity.

In this context, it is essential to analyze the key challenges associated with 5G and beyond wireless communication systems and explore potential technological solutions. This chapter aims to provide a comprehensive and technically rigorous **overview of these challenges, along with emerging trends and**

enabling technologies. The remainder of this chapter is organized as follows: Section 2 discusses the evolution of wireless communication systems, Section 3 highlights the key features of 5G networks, Section 4 presents the major challenges, Section 5 explores enabling technologies, Section 6 discusses beyond 5G (6G) paradigms, followed by applications, future research directions, and concluding remarks.

2. EVOLUTION OF WIRELESS COMMUNICATION (1G → 5G → BEYOND)

The evolution of wireless communication systems has been characterized by continuous advancements in transmission technologies, modulation schemes, multiple access techniques, and network architectures. Each generation has been developed to overcome the limitations of its predecessor while addressing the growing demand for higher data rates, improved quality of service (QoS), and enhanced connectivity.

FIRST GENERATION (1G): ANALOG COMMUNICATION

The first generation (1G) wireless systems, introduced in the 1980s, were primarily designed for analog voice communication. These systems utilized frequency modulation (FM) techniques and operated using circuit-switched networks.

Features:

- Analog voice transmission
- Frequency Division Multiple Access (FDMA)
- Limited capacity and poor voice quality

Limitations:

- Susceptibility to noise and interference
- Lack of security
- Inefficient spectrum utilization

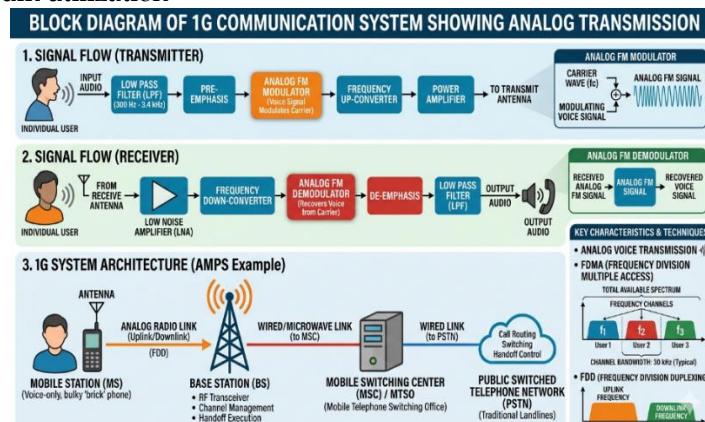

Figure 2.1 - 1G communication system

SECOND GENERATION (2G): DIGITAL COMMUNICATION

The second generation (2G) marked the transition from analog to digital communication, significantly improving voice quality and security. Technologies such as GSM and CDMA were widely adopted.

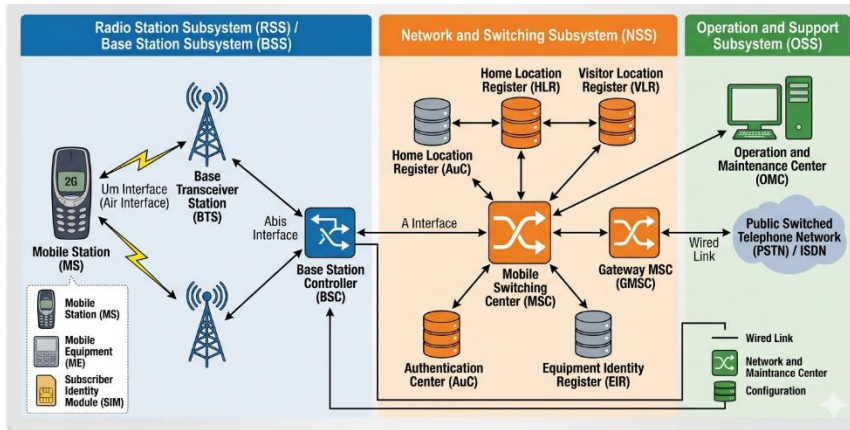

Figure 2.2 - Architecture of GSM network

Features:

- Digital voice communication
- Use of TDMA and CDMA
- SMS services

Limitations:

- Limited data rates (~64 kbps)
- Not suitable for multimedia applications

THIRD GENERATION (3G): MULTIMEDIA SUPPORT

The third generation (3G) systems were designed to support both voice and data services, enabling multimedia communication such as video calls and mobile internet access.

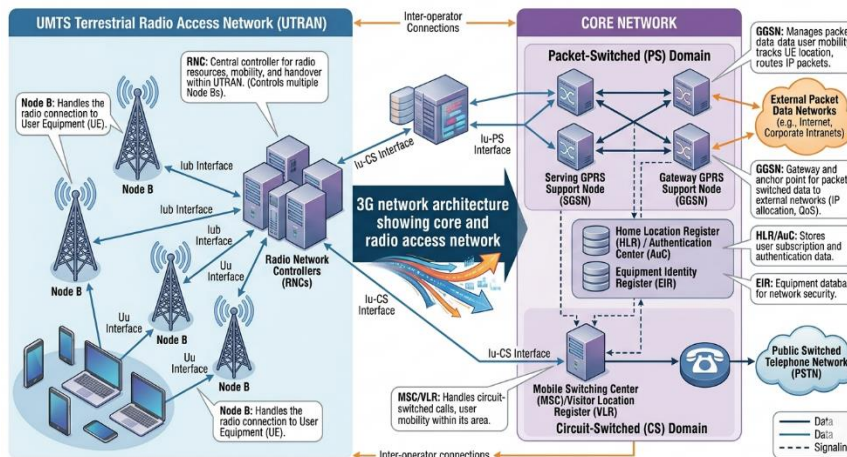

Figure 2.3: 3G network architecture

Features:

- Higher data rates (up to 2 Mbps)
- Wideband CDMA (WCDMA)
- Internet and video services

Limitations:

- High deployment cost

- Increased power consumption

FOURTH GENERATION (4G): BROADBAND IP-BASED WIRELESS SYSTEMS

The fourth generation (4G) wireless communication systems represent a major transition from circuit-switched and hybrid architectures to fully packet-switched, all-IP networks. The most prominent 4G standard is Long Term Evolution (LTE) and its advanced version LTE-Advanced, standardized by 3GPP.

Features

- All-IP Architecture:** 4G eliminates circuit switching entirely and adopts an all-IP core network known as the Evolved Packet Core (EPC), enabling seamless integration with internet services.
- Orthogonal Frequency Division Multiple Access (OFDMA):** Downlink transmission in LTE employs OFDMA, which divides the available bandwidth into multiple orthogonal subcarriers, improving spectral efficiency and robustness against multipath fading.

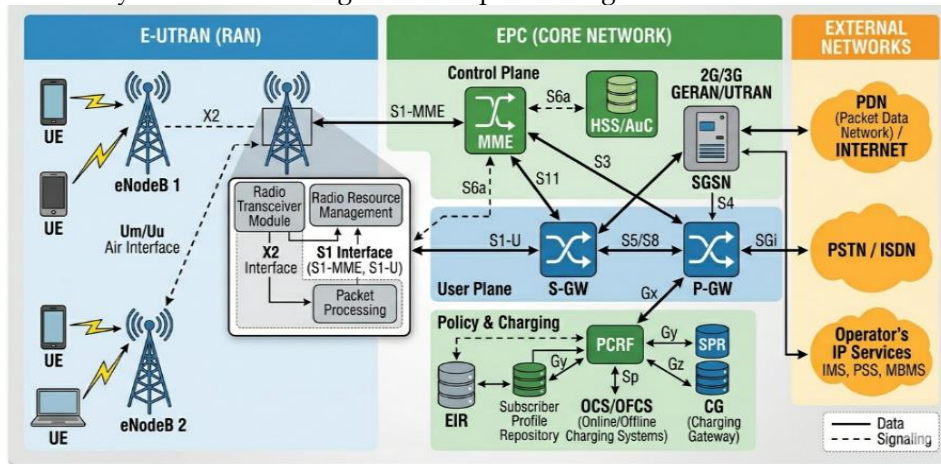

Figure 2.4: LTE architecture (E-UTRAN and EPC)

- Single Carrier FDMA (SC-FDMA):** Used in uplink to reduce Peak-to-Average Power Ratio (PAPR), making it suitable for mobile devices with limited battery capacity.
- Multiple Input Multiple Output (MIMO):** 4G systems use MIMO techniques (e.g., 2×2, 4×4 configurations) to improve data rates and link reliability through spatial multiplexing and diversity.
- Carrier Aggregation (LTE-Advanced):** Combines multiple frequency bands to increase bandwidth and achieve higher data rates.

Performance Metrics

- Peak data rate: Up to 1 Gbps (stationary users)
- Latency: ~10 ms
- Bandwidth: Up to 100 MHz (with aggregation)

Limitations of 4G Systems

- Limited support for massive IoT connectivity
- Increasing spectrum congestion in sub-6 GHz bands
- Higher latency compared to emerging applications (e.g., autonomous systems)
- Inefficient handling of ultra-reliable low-latency services

FIFTH GENERATION (5G): ULTRA-RELIABLE AND SCALABLE COMMUNICATION SYSTEMS

The fifth generation (5G) wireless systems are designed to address the limitations of 4G by enabling a flexible, scalable, and service-oriented architecture. Standardized under 3GPP Release 15 and beyond, 5G introduces a unified framework capable of supporting heterogeneous use cases.

Core Service Categories

5G is fundamentally built upon three service pillars:

- **Enhanced Mobile Broadband (eMBB):**
Supports high data rate applications such as 4K/8K video streaming, augmented reality (AR), and virtual reality (VR).
- **Ultra-Reliable Low-Latency Communication (URLLC):**
Designed for mission-critical applications such as autonomous vehicles, remote surgery, and industrial automation, requiring latency <1 ms and reliability >99.999%.
- **Massive Machine-Type Communication (mMTC):**
Enables connectivity for billions of IoT devices with low power consumption and sporadic data transmission.

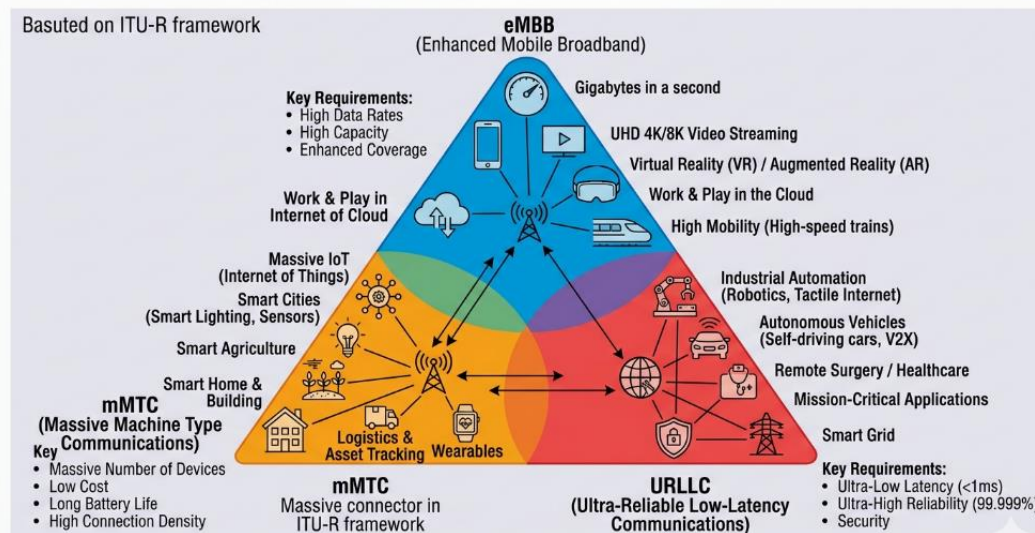

Figure 2.5(a): Illustration of eMBB, URLLC, and mMTC use cases

Key Enabling Technologies

- **Massive MIMO:** Utilizes a large number of antennas (e.g., 64×64 or higher) at the base station to achieve high spectral efficiency and spatial multiplexing gains.
- **Millimeter-Wave (mmWave) Communication:** Operates in frequency bands above 24 GHz, providing large bandwidth but facing challenges such as high path loss and signal blockage.
- **Beamforming:** Directional transmission technique that focuses energy toward the intended user, improving signal strength and reducing interference.
- **Network Slicing:** Allows the creation of multiple virtual networks over a shared physical infrastructure, each optimized for specific applications (e.g., IoT, healthcare, automotive).
- **Edge Computing (MEC):** Moves computation closer to the user, reducing latency and improving real-time performance.
- **Software-Defined Networking (SDN) & Network Function Virtualization (NFV):** Enable dynamic network configuration and efficient resource management.

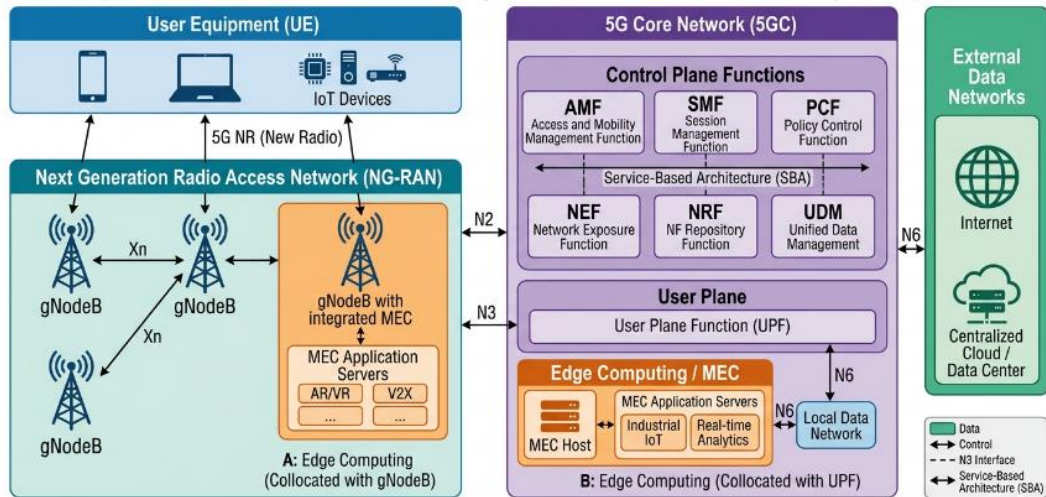

Figure 2.5(b): 5G architecture with gNodeB, core network, and edge computing

Performance Metrics

- Data rate: Up to 10 Gbps
- Latency: <1 ms (URLLC)
- Device density: Up to 10^6 devices/km²
- Bandwidth: Up to 400 MHz (sub-6 GHz), larger in mmWave

Challenges in 5G

- High propagation losses in mmWave bands
- Hardware complexity in massive MIMO systems
- Interference in ultra-dense networks
- Security vulnerabilities due to virtualization
- High deployment and infrastructure cost

BEYOND 5G (6G): TOWARDS INTELLIGENT AND UBIQUITOUS CONNECTIVITY

Beyond 5G, commonly referred to as 6G, aims to extend the capabilities of 5G by integrating intelligence, extreme data rates, and global connectivity. Although still in the research phase, 6G is expected to revolutionize communication systems by enabling new paradigms.

Technological Directions

- **Terahertz (THz) Communication:** Utilizes frequencies in the range of 0.1–10 THz, enabling ultra-high data rates (up to Tbps) but facing challenges in signal attenuation and hardware design.
- **Intelligent Reflecting Surfaces (IRS):** Artificially engineered surfaces that can dynamically control electromagnetic wave propagation to improve coverage and signal quality.
- **AI-Native Networks:** Integration of artificial intelligence for autonomous network management, resource allocation, and predictive optimization.
- **Integrated Space-Air-Ground-Sea Networks:** Combines terrestrial networks with satellite, UAV, and maritime communication systems to achieve global coverage.

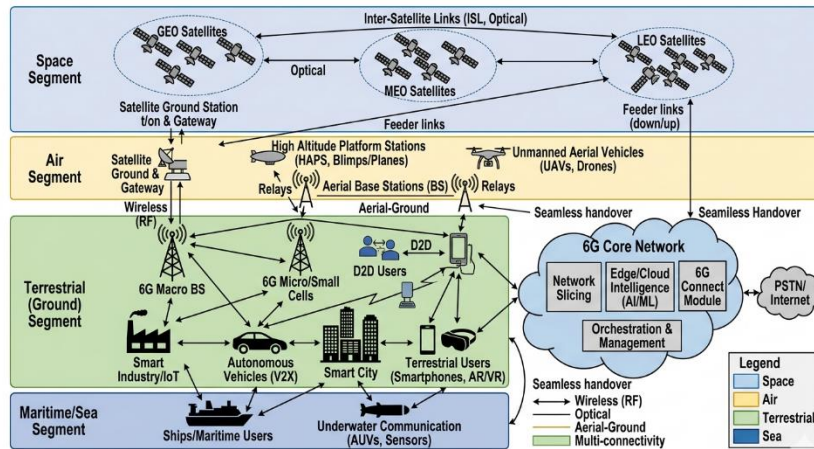

Figure 2.6: Integrated 6G architecture (space-air-ground network)

Expected Performance Targets

- Data rate: Up to 1 Tbps
- Latency: <0.1 ms
- Ultra-high reliability and intelligence
- Seamless global connectivity

Emerging Applications

- Holographic communication
- Digital twins
- Tactile internet
- Smart cities and autonomous ecosystems

COMPARATIVE ANALYSIS OF WIRELESS GENERATIONS

A comparative summary of different generations is essential for understanding the technological progression.

Table 1: Comparison of Wireless Generations

Generation	Technology	Data Rate	Key Features	Limitations
1G	Analog	~2.4 kbps	Voice only	Poor quality, no security
2G	GSM, CDMA	~64 kbps	Digital voice, SMS	Low data rate
3G	WCDMA	~2 Mbps	Multimedia support	High cost
4G	LTE	~1 Gbps	High-speed internet	Spectrum issues
5G	NR	~10 Gbps	IoT, low latency	Complexity
6G	Future	~1 Tbps	AI, THz, global connectivity	Under research

KEY FEATURES OF 5G NETWORKS

The fifth-generation (5G) wireless communication system introduces a paradigm shift from conventional mobile communication networks by enabling a flexible, scalable, and service-oriented architecture. Unlike previous generations that primarily focused on increasing data rates, 5G is designed to support heterogeneous applications with diverse performance requirements, including high throughput, ultra-low latency, massive connectivity, and high reliability.

5G SERVICE CATEGORIES

The design of 5G networks is fundamentally based on three primary service categories:

1. Enhanced Mobile Broadband (EMBB)

eMBB focuses on delivering high data rates and improved user experience for applications such as ultra-high-definition (UHD) video streaming, augmented reality (AR), and virtual reality (VR).

- Peak data rates up to 10 Gbps
- High spectral efficiency
- Seamless coverage in dense urban environments

2. Ultra-Reliable Low-Latency Communication (URLLC)

URLLC is designed for mission-critical applications where latency and reliability are crucial.

- Latency < 1 ms
- Reliability > 99.999%
- Applications: autonomous vehicles, remote surgery, industrial automation

3. Massive Machine-Type Communication (MMTC)

mMTC enables connectivity for a massive number of IoT devices with low power consumption.

- Device density: up to 10^6 devices/km²
- Energy-efficient communication
- Sporadic and low-data-rate transmission

5G NETWORK ARCHITECTURE

The 5G architecture consists of two main components:

- **5G New Radio (NR):** Radio access technology
- **5G Core (5GC):** Cloud-native core network

Key Architectural Features

- **Service-Based Architecture (SBA):** Network functions interact via APIs, enabling flexibility and scalability.
- **Control and User Plane Separation (CUPS):** Enhances efficiency by separating signaling and data transmission.
- **Cloud-Native Design:** Supports virtualization using containers and microservices.

MASSIVE MIMO SYSTEMS

Massive MIMO is one of the most critical technologies in 5G, employing a large number of antennas at the base station to serve multiple users simultaneously.

Advantages

- Increased spectral efficiency
- Improved energy efficiency
- Spatial multiplexing gain

The channel capacity for a MIMO system is given by:

$$C = B \log_2(1 + S/N)$$

Where:

C = Channel capacity

B = Bandwidth

S/N = Signal-to-noise ratio

In massive MIMO, capacity scales with the number of antennas, improving system performance significantly.

★ [Insert Figure 3.3: Massive MIMO system with multiple antennas at base station]

MILLIMETER-WAVE (MMWAVE) COMMUNICATION

5G utilizes mmWave frequency bands (24 GHz-100 GHz) to access large bandwidths and achieve high data rates.

Advantages

- Large available spectrum
- High data rates

Challenges

- High path loss
- Susceptibility to blockage
- Limited coverage

The free-space path loss is given by:

$$FSPL = (4\pi df/c)^2$$

Where:

d = distance

f = frequency

c = speed of light

BEAMFORMING TECHNIQUES

Beamforming is used to direct signals toward specific users instead of broadcasting in all directions.

Types of Beamforming

- Analog beamforming
- Digital beamforming
- Hybrid beamforming

Advantages

- Improved signal strength
- Reduced interference
- Enhanced coverage

NETWORK SLICING

Network slicing enables multiple virtual networks to coexist on a shared physical infrastructure.

Main Characteristics

- Customizable network services
- Isolation between slices
- Efficient resource utilization

Example:

- Slice 1 → Healthcare (URLLC)
- Slice 2 → IoT (mMTC)
- Slice 3 → Video streaming (eMBB)

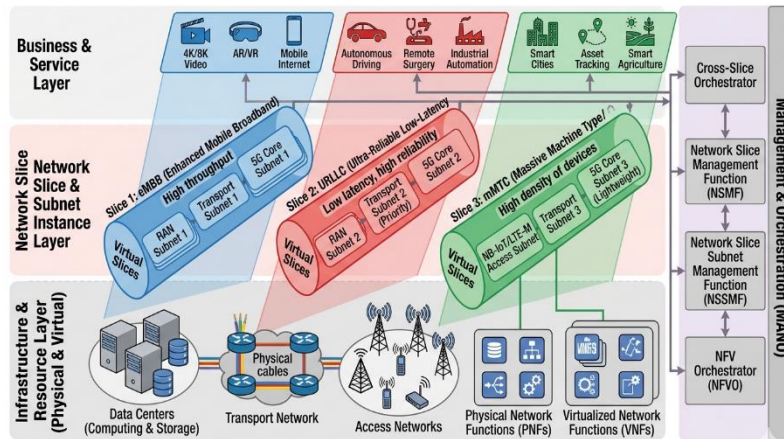

Figure 3.6: Network slicing architecture with multiple virtual slices

MULTI-ACCESS EDGE COMPUTING (MEC)

MEC brings computational capabilities closer to the user, reducing latency and improving real-time performance.

Benefits

- Reduced latency
- Lower backhaul load
- Real-time data processing

SPECTRAL EFFICIENCY AND PERFORMANCE METRICS

Spectral efficiency is a critical parameter in 5G systems, defined as:

$$\eta = R / B$$

Where:

R = data rate

B = bandwidth

5G aims to achieve significantly higher spectral efficiency compared to previous generations through advanced technologies such as massive MIMO and beamforming.

CHALLENGES IN 5G COMMUNICATION SYSTEMS

Despite the significant advancements introduced by 5G networks, several critical challenges hinder their efficient deployment and operation. These challenges arise due to the increasing complexity of network architectures, heterogeneous service requirements, and the use of higher frequency bands. This section provides a detailed analytical discussion of the major challenges in 5G communication systems.

SPECTRUM SCARCITY AND UTILIZATION

One of the most fundamental challenges in wireless communication is the limited availability of spectrum resources. The sub-6 GHz frequency bands, extensively used in previous generations, are already congested due to the proliferation of wireless services. Although 5G introduces mmWave bands to alleviate this issue, spectrum utilization remains inefficient due to:

- Fragmentation of available spectrum
- Underutilization in certain regions
- Dynamic variation in traffic demand

The achievable data rate is governed by the Shannon capacity theorem:

$$C = B \log_2(1 + \text{SNR})$$

Analytical Insight

- Increasing bandwidth B improves capacity but is limited by spectrum availability
- Increasing SNR is constrained by power and interference

Research Directions

- Dynamic Spectrum Access (DSA)
- Cognitive Radio Networks
- Spectrum sharing techniques

ENERGY EFFICIENCY AND POWER CONSUMPTION

The deployment of ultra-dense networks (UDNs) and massive MIMO systems significantly increases energy consumption in 5G networks. Base stations, in particular, contribute to a large portion of the total network power usage.

Energy efficiency is defined as:

$$EE = \frac{\text{Throughput}}{\text{Power Consumption}} \text{ (bits/Joule)}$$

Challenges

- High power consumption in massive MIMO arrays
- Continuous operation of small cells
- Increased computational load due to AI-driven optimization

Analytical Perspective

Total power consumption can be modeled as:

$$P_{\text{total}} = P_{\text{tx}} + P_{\text{circuit}} + P_{\text{processing}}$$

Where:

P_{tx} : Transmission power

P_{circuit} : Hardware-related power

$P_{\text{processing}}$: Signal processing and computation

Research Directions

- Green communication technologies
- Energy-efficient hardware design
- Sleep mode mechanisms for base stations

NETWORK DENSIFICATION AND ULTRA-DENSE NETWORKS (UDNS)

To meet the growing demand for high data rates, 5G networks deploy a large number of small cells, leading to ultra-dense network architectures.

Advantages

- Improved coverage
- Increased capacity

Challenges

- Increased inter-cell interference
- Complex mobility management
- Backhaul congestion

Analytical Model

The Signal-to-Interference-plus-Noise Ratio (SINR) is a key performance metric:

$$\text{SINR} = \frac{P_s}{I + N}$$

Where:

- P_s : Signal power
- I : Interference power

- N: Noise power \

As cell density increases:

- I increases → SINR decreases
- Network performance degrades if not properly managed

Research Directions

- Interference coordination techniques (ICIC, eICIC)
- Self-organizing networks (SON)
- Advanced handover mechanisms

INTERFERENCE MANAGEMENT

Interference is a major limiting factor in 5G networks, especially in dense deployments and mmWave communications.

Types of Interference

- Co-channel interference
- Inter-cell interference
- Cross-tier interference (macro vs small cells)

Analytical Insight

Interference power is typically modeled as:

$$I = \sum_{i=1}^N P_i h_i$$

Where:

P_i: Interfering signal power

h_i: Channel gain

Challenges

- Dynamic and unpredictable interference patterns
- Beam misalignment in mmWave systems
- Interference in shared spectrum environments

Research Directions

- Coordinated Multi-Point (CoMP)
- Interference alignment techniques
- AI-based interference prediction

SECURITY AND PRIVACY ISSUES

The adoption of software-defined networking (SDN), network function virtualization (NFV), and cloud-native architectures introduces new security challenges in 5G networks.

Key Vulnerabilities

- Distributed Denial of Service (DDoS) attacks
- Unauthorized access in virtualized environments
- Data privacy breaches in IoT devices

Analytical Perspective

Security risk can be expressed as:

Risk=Probability × Impact

Challenges

- Increased attack surface due to virtualization
- Lack of standardized security frameworks
- Heterogeneous device ecosystem

Research Directions

- Blockchain-based security frameworks
- AI-driven intrusion detection systems
- Secure network slicing

HARDWARE AND IMPLEMENTATION CHALLENGES

The implementation of advanced technologies such as massive MIMO and mmWave communication introduces several hardware-related challenges.

Major Issues

- RF hardware complexity
- High cost of deployment
- Thermal management in dense systems

Challenges

- Designing efficient power amplifiers for high frequencies
- Synchronization in large antenna arrays
- Scalability of hardware components

ENABLING TECHNOLOGIES FOR 5G AND BEYOND

To address the challenges discussed in the previous section, several advanced technologies have been developed and integrated into 5G systems, with further enhancements envisioned for beyond 5G (B5G) and 6G networks. These technologies aim to improve spectral efficiency, energy efficiency, network flexibility, and overall system intelligence.

ADVANCED MASSIVE MIMO SYSTEMS

Massive MIMO plays a crucial role in improving spectral efficiency and network capacity by exploiting spatial multiplexing and diversity gains.

Technical Advancements

- Use of large-scale antenna arrays (e.g., 64×64, 128×128)
- Hybrid beamforming to reduce hardware complexity
- Channel state information (CSI) optimization

The spectral efficiency for a multi-user MIMO system can be expressed as:

$$R = \sum_{k=1}^K \log_2(1 + \text{SINR}_k)$$

Where:

K = number of users

SINR_k = SINR of the kth user

Benefits

- Increased capacity
- Reduced interference through spatial separation
- Improved energy efficiency

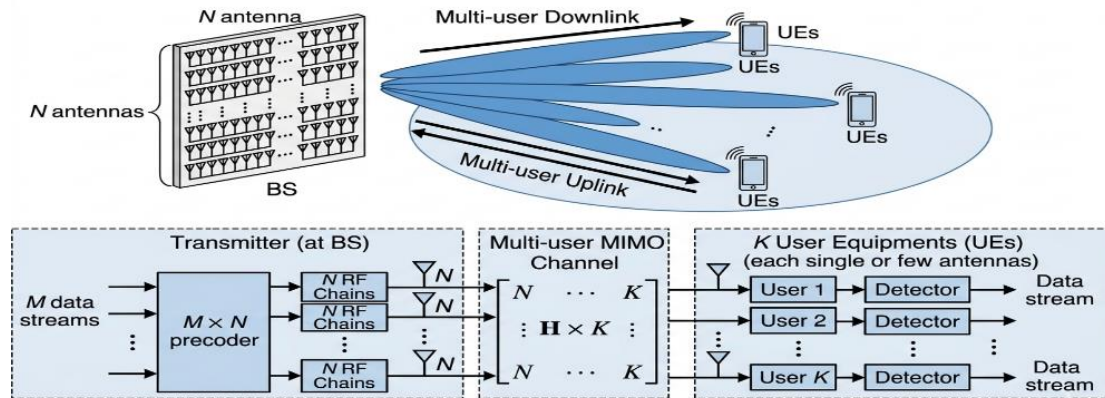

Figure 5.1: Multi-user massive MIMO system model

MILLIMETER-WAVE (MMWAVE) OPTIMIZATION

Although mmWave provides large bandwidth, its propagation limitations require advanced optimization techniques.

Technical Solutions

- Beam steering and adaptive beamforming
- Dense small cell deployment
- Blockage-aware routing

Analytical Insight

Received power in mmWave systems:

$$P_r = P_t G_t G_r (\lambda / 4\pi d)^2$$

Where:

G_t, G_r : antenna gains

λ : wavelength

Challenges:

- Path loss mitigation
- Improved coverage
- Enhanced signal reliability

ARTIFICIAL INTELLIGENCE AND MACHINE LEARNING IN WIRELESS NETWORKS

AI and ML are increasingly being integrated into wireless networks to enable intelligent decision-making and autonomous optimization.

Applications

- Dynamic resource allocation
- Interference prediction and mitigation
- Traffic forecasting
- Network fault detection

Analytical Perspective

A typical ML optimization model:

$$y = f(x; \theta)$$

Where:

x : input features (network parameters)

θ : model parameters

y : predicted output (e.g., optimal resource allocation)

Benefits

- Reduced operational complexity
- Improved network performance
- Adaptive and self-organizing networks

NETWORK SLICING AND VIRTUALIZATION

Network slicing enables the creation of multiple virtual networks tailored for specific applications on a shared physical infrastructure.

Technical Features

- End-to-end slice isolation
- Dynamic resource allocation
- Integration with SDN and NFV

Resource allocation in slicing can be modeled as:

$$R_{total} = \sum_{i=1}^N R_i$$

Where:

R_i: resources allocated to slice i

Benefits

- Customization for diverse applications
- Efficient resource utilization
- Improved QoS

INTELLIGENT REFLECTING SURFACES (IRS)

IRS is an emerging technology that enhances wireless communication by intelligently controlling signal propagation.

Working Principle

- Passive elements reflect signals with adjustable phase shifts
- Improves signal strength without active transmission

Analytical Insight

Reflected signal model:

$$y = \sum_{n=1}^N \alpha_n e^{j\theta_n}$$

Where:

- α_n : reflection amplitude
- θ_n : phase shift

Advantages

- Energy-efficient communication
- Improved coverage in blocked environments
- Reduced interference

TERAHERTZ (THZ) COMMUNICATION

THz communication is a key enabler for beyond 5G and 6G systems, offering extremely high data rates.

Features

- Frequency range: 0.1–10 THz
- Ultra-high bandwidth availability

Challenges Addressed

- Spectrum scarcity
- Ultra-high data rate requirements

Limitations

- Severe propagation loss
- Hardware design complexity

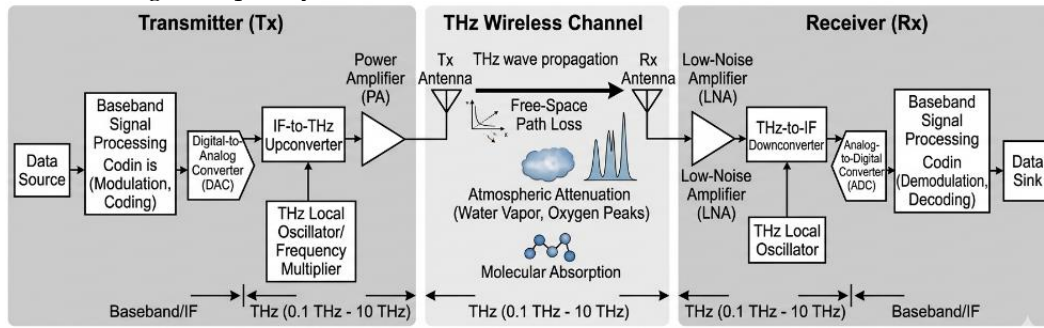

Figure 5.6: THz communication system model

EDGE COMPUTING AND CLOUD INTEGRATION

Edge computing complements 5G by bringing computational resources closer to end users.

Key Functions

- Real-time data processing
- Reduced latency
- Load balancing

Benefits

- Improved QoS
- Efficient network operation
- Reduced backhaul traffic

BEYOND 5G (6G VISION: ARCHITECTURE, TECHNOLOGIES, AND RESEARCH DIRECTIONS)

The evolution toward sixth-generation (6G) wireless communication systems is driven by the need to support ultra-high data rates, near-zero latency, intelligent network management, and seamless global connectivity. While 5G addresses many limitations of previous generations, it is still insufficient for emerging applications such as holographic communication, digital twins, tactile internet, and fully autonomous systems. Consequently, 6G is envisioned as an **AI-native, ultra-reliable, and ubiquitous communication paradigm**.

VISION AND KEY PERFORMANCE TARGETS

6G aims to significantly outperform 5G in all major performance metrics.

Expected Performance Enhancements

- Data rate: up to **1 Tbps**
- Latency: **< 0.1 ms**
- Reliability: **> 99.99999%**
- Device density: **10^7 devices/km²**
- Energy efficiency: **10–100× improvement over 5G**

Analytical Perspective

The data rate can be expressed as:

$$R = B \log_2(1 + \text{SINR})$$

6G NETWORK ARCHITECTURE

The 6G architecture is expected to move beyond traditional cellular structures and adopt a **fully integrated multi-layer network model**.

Main Layers

- **Space Layer:** Satellites for global coverage
- **Air Layer:** UAVs and high-altitude platforms
- **Ground Layer:** Terrestrial base stations
- **Sea Layer:** Maritime communication systems

Architectural Features

- AI-native design
- Fully distributed and decentralized control
- Integration of communication, sensing, and computing

TERAHERTZ (THZ) COMMUNICATION

THz communication is a cornerstone of 6G, enabling ultra-high data rates due to vast available bandwidth.

Technical Characteristics

- Frequency range: 0.1–10 THz
- Extremely high bandwidth

Challenges

- Severe attenuation
- Molecular absorption
- Hardware limitations

INTELLIGENT REFLECTING SURFACES (IRS) AND SMART ENVIRONMENTS

6G networks are expected to incorporate programmable environments using IRS to control electromagnetic wave propagation.

Key Concepts

- Passive beamforming
- Reconfigurable wireless environment
- Signal enhancement without additional power

Advantages

- Improved coverage
- Reduced energy consumption
- Enhanced signal quality

AI-NATIVE WIRELESS NETWORKS

Unlike 5G, where AI is used as an add-on, 6G networks are expected to be inherently AI-driven.

Applications

- Autonomous network management
- Predictive maintenance
- Intelligent spectrum allocation
- Self-optimization

Benefits

- Reduced human intervention
- Adaptive and self-learning networks
- Improved efficiency

INTEGRATED SENSING, COMMUNICATION, AND COMPUTING (ISCC)

6G will integrate communication with sensing and computing, enabling advanced applications such as environmental monitoring and autonomous systems.

Key Features

- Joint communication and radar sensing
- Real-time data analytics
- Edge intelligence

Applications

- Autonomous vehicles
- Smart cities
- Industrial automation

KEY RESEARCH CHALLENGES IN 6G

Despite its promising vision, 6G faces several open research challenges:

Technical Challenges

- Efficient THz hardware design
- Accurate channel modeling at high frequencies
- Scalability of AI-driven networks
- Integration of heterogeneous network layers

Operational Challenges

- Standardization and regulation
- Cost-effective deployment
- Security in AI-driven systems

RESEARCH ROADMAP AND FUTURE DIRECTIONS

The development of 6G requires interdisciplinary research efforts in:

- Advanced materials for THz devices
- Machine learning and AI algorithms
- Quantum communication technologies
- Sustainable and green communication systems

APPLICATIONS AND USE CASES OF 5G AND BEYOND WIRELESS SYSTEMS

The deployment of 5G and the vision of beyond 5G (6G) networks are driven by their ability to support a wide range of applications across multiple domains. These applications leverage the key capabilities of high data rates, ultra-low latency, massive connectivity, and intelligent network management.

SMART CITIES AND URBAN INFRASTRUCTURE

5G enables the development of smart cities by integrating communication technologies with urban infrastructure.

Key Applications

- Intelligent traffic management systems
- Smart street lighting
- Waste management and environmental monitoring
- Technical Perspective
- Real-time data collection using IoT sensors
- Edge computing for low-latency decision-making
- AI-based analytics for predictive control

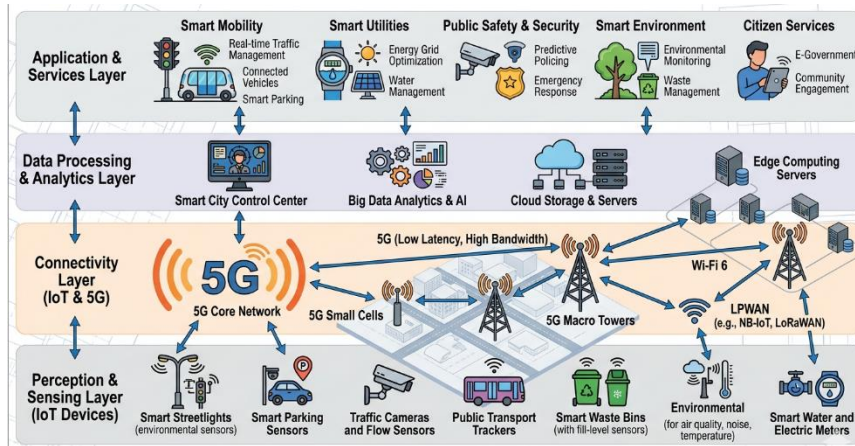

Figure 7.1: Smart city architecture with IoT and 5G connectivity

HEALTHCARE AND TELEMEDICINE

5G and beyond technologies revolutionize healthcare by enabling remote diagnosis, monitoring, and surgical procedures.

Key Applications

- Remote surgery using robotic systems
- Real-time patient monitoring
- Wearable health devices

Technical Requirements

- URLLC for ultra-low latency and high reliability
- Secure data transmission
- Edge computing for real-time processing

INDUSTRIAL AUTOMATION (INDUSTRY 4.0)

5G plays a crucial role in enabling smart manufacturing and industrial automation.

Applications

- Autonomous robots
- Predictive maintenance
- Real-time process control

Technical Perspective

- Low latency communication for machine coordination
- High reliability for mission-critical operations
- Integration with AI and IoT

AUTONOMOUS VEHICLES AND INTELLIGENT TRANSPORTATION SYSTEMS

5G and 6G enable communication between vehicles, infrastructure, and pedestrians.

Applications

- Vehicle-to-Vehicle (V2V) communication
- Vehicle-to-Infrastructure (V2I) systems
- Autonomous driving

Technical Requirements

- Ultra-low latency (<1 ms)
- High reliability
- Edge computing for real-time decision-making

INTERNET OF THINGS (IOT) AND SMART DEVICES

Massive Machine-Type Communication (mMTC) supports billions of connected devices.

Applications

- Smart homes
- Environmental monitoring
- Smart agriculture

Technical Perspective

- Energy-efficient communication protocols
- Massive connectivity
- Scalable network architecture

IMMERSIVE TECHNOLOGIES: AR, VR, AND XR

5G and 6G enable immersive experiences through high data rates and low latency.

Applications

- Virtual reality (VR) gaming
- Augmented reality (AR) in education and training
- Extended reality (XR) applications

Technical Requirements

- High bandwidth (Gbps range)
- Low latency (<10 ms)
- Edge rendering and processing

SMART AGRICULTURE

Wireless communication technologies are transforming agriculture through automation and data-driven decision-making.

Applications

- Precision farming
- Soil and crop monitoring
- Automated irrigation systems

Technical Perspective

- IoT sensors for real-time monitoring
- AI-based analytics
- Remote control of agricultural equipment

HOLOGRAPHIC COMMUNICATION AND DIGITAL TWINS (6G APPLICATIONS)

6G networks are expected to enable futuristic applications that require extremely high data rates and low latency.

Applications

- Holographic telepresence
- Digital twin systems for real-time simulation
- Remote collaboration environments

Technical Requirements

- Tbps data rates
- Ultra-low latency (<0.1 ms)
- AI-driven processing

OPEN RESEARCH CHALLENGES AND FUTURE SCOPE

Despite the remarkable advancements in 5G and the promising vision of beyond 5G (6G) systems, several open research challenges remain unresolved. These challenges span across multiple domains, including spectrum management, hardware design, and network intelligence, security, and system integration. Addressing these issues is essential for realizing the full potential of next-generation wireless communication systems.

SPECTRUM MANAGEMENT AND DYNAMIC ALLOCATION

Efficient utilization of the radio spectrum continues to be a fundamental challenge due to increasing demand and limited availability.

Open Issues

- Static spectrum allocation policies
- Underutilization of licensed bands
- Coexistence of heterogeneous networks

Research Directions

- AI-driven dynamic spectrum allocation
- Cognitive radio and opportunistic spectrum access
- Spectrum sharing frameworks (licensed shared access, unlicensed bands)

Future Scope

The integration of AI with spectrum management can enable real-time adaptive allocation, improving spectral efficiency and reducing interference.

ENERGY EFFICIENCY AND SUSTAINABLE COMMUNICATION

The exponential growth in network infrastructure and connected devices leads to increased energy consumption, raising concerns about sustainability.

Open Issues

- High energy consumption in ultra-dense networks
- Inefficient power utilization in massive MIMO systems
- Environmental impact of communication networks

Research Directions

- Green communication technologies
- Energy harvesting and wireless power transfer
- AI-based energy optimization

Future Scope

Future networks will focus on achieving **carbon-neutral communication systems** through sustainable design and intelligent resource management.

AI-NATIVE NETWORK DESIGN AND OPTIMIZATION

The integration of AI into wireless networks introduces new opportunities and challenges.

Open Issues

- Lack of reliable training datasets
- Model generalization across dynamic environments
- High computational complexity

Research Directions

- Federated learning for distributed networks
- Reinforcement learning for dynamic resource allocation

- Explainable AI for network decision-making

Future Scope

AI-native networks will enable fully autonomous, self-optimizing communication systems with minimal human intervention.

SECURITY, PRIVACY, AND TRUST MANAGEMENT

As wireless networks become more complex and interconnected, ensuring security and privacy becomes increasingly challenging.

Open Issues

- Vulnerabilities in virtualized and cloud-based architectures
- Data privacy concerns in IoT and edge computing
- Security threats in AI-driven systems

Research Directions

- Blockchain-based secure communication
- Quantum cryptography
- AI-based intrusion detection systems

Future Scope

Future networks must incorporate end-to-end security **frameworks** with built-in trust mechanisms and real-time threat detection.

TERAHERTZ COMMUNICATION AND HARDWARE CONSTRAINTS

While THz communication offers significant advantages, it introduces substantial hardware and propagation challenges.

Open Issues

- High signal attenuation and molecular absorption
- Lack of efficient THz transceivers
- Limited channel modeling accuracy

Research Directions

- Advanced materials for THz devices
- Hybrid communication systems (mmWave + THz)
- Novel modulation and coding schemes

Future Scope

Breakthroughs in material science and device engineering will be essential for practical THz communication deployment.

INTEGRATED NETWORK ARCHITECTURE AND INTEROPERABILITY

The integration of multiple network layers (space, air, ground, sea) introduces significant design challenges.

Open Issues

- Interoperability among heterogeneous networks
- Synchronization across multiple layers
- Resource allocation in multi-tier systems

Research Directions

- Unified network architecture frameworks
- Cross-layer optimization techniques
- Standardization of protocols

Future Scope

Future communication systems will adopt **fully integrated and interoperable architectures** to ensure seamless connectivity across all domains.

ULTRA-LOW LATENCY AND RELIABILITY CONSTRAINTS

Meeting the stringent requirements of ultra-low latency and high reliability remains a critical challenge.

Open Issues

- Processing delays in network nodes
- Transmission delays in high-frequency bands
- Trade-offs between latency and reliability

Analytical Insight

End-to-end latency can be expressed as:

$$T_{\text{total}} = T_{\text{transmission}} + T_{\text{processing}} + T_{\text{queueing}}$$

Research Directions

- Edge computing and distributed processing
- Network optimization algorithms
- Low-latency communication protocols

Future Scope

Future networks will enable **near-instantaneous communication**, supporting applications such as tactile internet and real-time control systems.

STANDARDIZATION AND REGULATORY CHALLENGES

The deployment of next-generation wireless systems requires global standardization and regulatory alignment.

Open Issues

- Spectrum regulation across countries
- Lack of unified global standards
- Policy and governance issues

Research Directions

- International collaboration for standardization
- Flexible regulatory frameworks
- Policy-driven spectrum management

Future Scope

Global cooperation will be essential to ensure the successful implementation and adoption of 6G technologies.

CONCLUSION

The rapid evolution of wireless communication systems from early-generation networks to fifth-generation (5G) technologies has fundamentally transformed the way information is transmitted, processed, and utilized across diverse domains. 5G networks, with their capability to support enhanced mobile broadband (eMBB), ultra-reliable low-latency communication (URLLC), and massive machine-type communication (mMTC), have laid the foundation for a highly connected and data-driven digital ecosystem. However, as discussed throughout this chapter, the deployment and operation of 5G systems are accompanied by several critical challenges, including spectrum scarcity, energy inefficiency, network densification, interference management, and security vulnerabilities.

To address these challenges, a range of enabling technologies such as massive MIMO, millimeter-wave communication, network slicing, edge computing, and artificial intelligence-driven optimization have

been explored. These technologies not only enhance the performance of current systems but also pave the way for the realization of beyond 5G (B5G) and sixth-generation (6G) communication networks. The integration of advanced concepts such as intelligent reflecting surfaces, terahertz communication, AI-native network architectures, and integrated space-air-ground-sea networks highlights the transformative potential of next-generation wireless systems.

Furthermore, the application domains of 5G and beyond networks—including smart cities, healthcare, industrial automation, autonomous transportation, and immersive technologies—demonstrate their far-reaching societal and technological impact. These applications demand not only high performance but also reliability, security, and sustainability, thereby necessitating continuous research and innovation.

Despite the promising advancements, several open research challenges remain, particularly in areas such as dynamic spectrum management, energy-efficient system design, AI integration, hardware limitations, and global standardization. Addressing these challenges requires interdisciplinary collaboration among researchers, industry stakeholders, and policymakers.

In conclusion, the transition from 5G to beyond 5G and 6G represents not merely an incremental improvement but a paradigm shift toward intelligent, adaptive, and ubiquitous communication systems. The future of wireless communication lies in the seamless integration of communication, computation, sensing, and intelligence, enabling a fully connected world that supports emerging applications and drives sustainable technological growth. This chapter has provided a comprehensive and technically rigorous overview of the challenges, enabling technologies, and future directions, serving as a foundation for further research and development in next-generation wireless communication systems.

REFERENCES (IEEE FORMAT)

1. 3rd Generation Partnership Project (3GPP), "Study on Scenarios and Requirements for Next Generation Access Technologies," TR 38.913, 2017.
2. International Telecommunication Union (ITU), "IMT Vision – Framework and Overall Objectives of the Future Development of IMT for 2020 and Beyond," ITU-R M.2083-0, 2015.
3. Theodore S. Rappaport et al., *Millimeter Wave Wireless Communications*, Pearson, 2015.
4. Erik Dahlman, Stefan Parkvall, and Johan Skold, *5G NR: The Next Generation Wireless Access Technology*, Academic Press, 2018.
5. Andrea Goldsmith, *Wireless Communications*, Cambridge University Press, 2005.
6. David Tse and Pramod Viswanath, *Fundamentals of Wireless Communication*, Cambridge University Press, 2005.
7. IEEE, "IEEE Standard for 5G and Future Networks," *IEEE Communications Magazine*, various issues.
8. Qualcomm, "The 5G Economy: How 5G Technology Will Contribute to the Global Economy," *White Paper*, 2020.
9. Nokia, "6G White Paper: Key Drivers and Research Challenges," 2020.
10. Samsung, "6G: The Next Hyper-Connected Experience for All," *White Paper*, 2020.
11. Ian F. Akyildiz, Josep M. Jornet, "Realizing Ultra-Massive MIMO (UM-MIMO) Communication in the Terahertz Band," *IEEE Transactions on Communications*, vol. 64, no. 6, 2016.
12. Marco Di Renzo et al., "Smart Radio Environments Empowered by Reconfigurable Intelligent Surfaces," *IEEE Communications Magazine*, vol. 58, no. 1, 2020.
13. Geoffrey Hinton et al., "Deep Learning," *Nature*, vol. 521, 2015.
14. Ericsson, "Mobility Report," 2023.

15. Huawei, "6G White Paper: Vision and Key Technologies," 2021.
16. Cisco, "Annual Internet Report," 2023.
17. Saad Bennis et al., "Ultra-Reliable and Low-Latency Wireless Communication: Tail, Risk and Scale," *Proceedings of the IEEE*, 2018.
18. Petar Popovski et al., "Wireless Access for Ultra-Reliable Low-Latency Communication," *IEEE Network*, 2018.
19. M. Giordani et al., "Toward 6G Networks: Use Cases and Technologies," *IEEE Communications Magazine*, 2020.
20. Walid Saad et al., "Vision of 6G Wireless Systems: Applications, Trends, Technologies, and Open Research Problems," *IEEE Network*, 2020.
21. C.-X. Wang et al., "On the Road to 6G: Visions, Requirements, Key Technologies and Testbeds," *IEEE Communications Surveys & Tutorials*, 2023.
22. W. Chen et al., "5G-Advanced Towards 6G: Past, Present, and Future," *IEEE Communications Magazine*, 2023.
23. S. A. H. Mohsan and Y. Li, "A Contemporary Survey on 6G Wireless Networks: Potentials, Advances, Challenges and Future Trends," *IEEE Access*, 2023.
24. Z. Wei et al., "Integrated Sensing and Communication Toward 5G-Advanced and 6G: A Survey," *IEEE Communications Surveys & Tutorials*, 2023.
25. International Telecommunication Union (ITU), "IMT-2030 Framework for 6G," ITU-R M.2160-0, 2023.
26. 3rd Generation Partnership Project (3GPP), "5G-Advanced Release 18 Overview," TR 21.918, 2024.
27. X. Lin et al., "5G Advanced Evolution and Standardization in 3GPP," *IEEE Communications Standards Magazine*, 2023.
28. W. Saad et al., "A Vision of 6G Wireless Systems: Applications, Trends, Technologies, and Open Research Problems," *IEEE Network*, 2023.
29. P. Popovski et al., "Wireless Access for 6G: Key Challenges and Enabling Technologies," *IEEE Communications Magazine*, 2023.
30. M. Giordani et al., "Toward 6G Networks: Use Cases and Technologies," *IEEE Access*, 2023.
31. L. Dai et al., "Reconfigurable Intelligent Surfaces for 6G: Recent Advances and Future Trends," *IEEE Communications Surveys & Tutorials*, 2023.
32. J. M. Jornet et al., "Terahertz Communication for 6G Systems: Challenges and Opportunities," *IEEE Communications Magazine*, 2023.
33. G. Fettweis et al., "The 6G Vision: Toward Distributed Intelligence in Wireless Networks," *IEEE Vehicular Technology Magazine*, 2024.
34. I. F. Akyildiz et al., "6G Roadmap: Vision, Key Technologies, and Research Challenges," *IEEE Communications Magazine*, 2024.
35. E. Hossain et al., "Machine Learning for Next-Generation Wireless Networks," *IEEE Communications Surveys & Tutorials*, 2024.
36. R. Zhang et al., "Energy-Efficient Communication for 5G and Beyond: Recent Advances," *IEEE Wireless Communications*, 2023.
37. M. Di Renzo et al., "Smart Radio Environments Empowered by Intelligent Reflecting Surfaces," *IEEE Communications Magazine*, 2023.
38. S. Bennis et al., "Ultra-Reliable Low-Latency Communication in 6G Systems: Advances and Challenges," *IEEE Network*, 2024.
39. A. Alam et al., "KHz to THz: Unified Trends in RF Frequency Scaling," *IEEE Access*, 2026.
40. L. Zhang et al., "Toward Efficient 6G IoT Networks: Resource Optimization and Future Directions," *IEEE Access*, 2024.